

Models: **12RESL/12RESM1**

KOHLER POWER SYSTEMS

Multi-Fuel
LP Vapor/Natural Gas



Standard Features

- Powerful
 - The Model 12RESL/12RESM1 is powerful enough to start and run a typical 4 ton (48,000 BTU) central air conditioner *
- Designed for easy installation
 - Polymer base eliminates the need for a concrete mounting pad, reducing installation time and cost
 - Factory-connected pre-wire kit simplifies electrical connections
 - Flexible fuel line provided
 - Designed for outdoor installation only
- Quiet
 - Quiet operation: 65 dB(A) at 7 m, similar to a typical vacuum cleaner
 - Sound enclosure maintains neighborhood solitude
 - Internal exhaust system with a USDA Forest Service-approved spark arrestor
- DC 2200 Digital Control is designed for today's most sophisticated electronics
 - Digital voltage regulator
 - LED display provides diagnostic capability
- Engine features
 - Digital Spark Advance Module (DSAM) optimizes engine performance for natural gas and LP vapor fuels
 - Simple field-conversion between natural gas and LP vapor fuels while maintaining emission certification
- AC-powered 6-amp battery charger
- Integral vibration isolation
- Generator set and components are prototype-tested, factory-built, and production-tested



- UL 2200 listed
- UL listed to Canadian safety standards
- Emission Certifications
 - California Air Resources Board (CARB)-certified for both LP vapor and natural gas (field-convertible)
 - Meets Environmental Protection Agency (EPA) nonstationary unit requirements
- Kohler Co. provides one-source responsibility for the generating system and accessories
- A five-year limited warranty covers all systems and components

Power System Package

- Model 12RESL/12RESM1 generator set
- 100 Amp Model RDT automatic transfer switch with 12-circuit load center for connection of essential loads
- Prewire kit for quick and easy installation

Generator Ratings

Alternator Model	Voltage	Phase	Hz	Standby Amps		Standby Ratings, kW/kVA	
				Natural Gas	LP Gas	Natural Gas	LP Gas
2F4	120/240	1	60	43	50	10.4/10.4	12.0/12.0

RATINGS: Standby ratings apply to installations served by a reliable utility source. All single-phase units are rated at 1.0 power factor. The standby rating is applicable to variable loads with an average load factor of 80% for the duration of the power outage. No overload capacity is specified at this rating. Ratings are in accordance with ISO-3046/1, BS5514, AS2789, and DIN 6271. GENERAL GUIDELINES FOR DERATING: *ALTITUDE*: Derate 4% per 305 m (1000 ft.) elevation above 153 m (500 ft.). *TEMPERATURE*: Derate 1.5% per 5.5°C (10°F) temperature increase above 16°C (60°F). Availability is subject to change without notice. Kohler Co. reserves the right to change the design or specifications without notice and without any obligation or liability whatsoever. Contact your local Kohler Co. generator distributor for availability.

* Due to the cycling operation of many electrical appliances, the generator set may not run all appliances simultaneously. Check the appliance manufacturer's specifications for actual power requirements. Consult a Kohler® Power Systems professional for your exact residential power system requirements.

Application Data

Engine

Engine Specifications	60 Hz
Manufacturer	Kohler
Engine: model, type	CH740 4-Cycle
Cylinder arrangement	V-2
Displacement, L (cu. in.)	0.725 (44)
Bore and stroke, mm (in.)	83 x 67 (3.27 x 2.64)
Compression ratio	9.0:1
Main bearings: quantity, type	2, Parent Material
Rated rpm	3600
Max. engine power at rated rpm, kW (HP)	
CH740, LP vapor	17.6 (23.6)
CH740, natural gas	15.3 (20.5)
Cylinder head material	Aluminum
Valve material	Steel/Stellite®
Piston type and material	Aluminum Alloy
Crankshaft material	Heat Treated, Ductile Iron
Governor: type	Mechanical
Frequency regulation, steady state	±1.25%
Air cleaner type	Dry

Engine Electrical

Engine Electrical System	
Ignition system	Electronic, DSAM
Starter motor rated voltage (DC)	12
Battery charger, ampere rating	6
Battery (purchased separately):	
Ground	Negative
Volts (DC)	12
Battery quantity	1
Recommended cold cranking amps (CCA) rating for -18°C (0°F)	525
Maximum dimensions, L x W x H, mm (in.)	210 x 178 x 197 (8.25 x 7.00 x 7.75)

Exhaust

Exhaust System	
Exhaust flow at rated kW, m ³ /min. (cfm)	3.8 (135)
Exhaust temperature at rated kW, dry exhaust, °C (°F)	760 (1400)

Operation Requirements

Cooling Air	
Total inlet air, m ³ /min. (cfm)	28.0 (990)
Cooling air, m ³ /min. (cfm)	26.9 (950)
Combustion air, m ³ /min. (cfm)	1.1 (39.2)

Lubrication

Lubricating System	
Type	Full Pressure
Oil capacity (with filter), L (qt.)	1.9 (2.0)
Oil filter: quantity, type	1, Cartridge
Oil cooler	Integral

Fuel Requirements

Fuel System	
Fuel types	Natural Gas or LP Vapor
Fuel supply inlet	1/2 NPT
Fuel supply pressure, kPa (in. H ₂ O):	
Natural gas	1.2-2.7 (5-11)
LP	1.7-2.7 (7-11)

Minimum Gas Pipe Size Recommendation, in. NPT

Pipe Length, m (ft.)	Natural Gas (193,000 Btu/hr.)	LP Vapor (203,000 Btu/hr.)
8 (25)	3/4	3/4
15 (50)	1	3/4
30 (100)	1	1
46 (150)	1 1/4	1
61 (200)	1 1/4	1

Fuel Consumption at % rated load

% Load	
Natural Gas, m ³ /hr. (cfh)	
100%	5.4 (193)
75%	4.7 (163)
50%	3.5 (124)
25%	2.6 (93)
LP Vapor, m ³ /hr. (cfh)	
100%	2.3 (81)
75%	2.1 (75)
50%	1.8 (60)
25%	1.2 (45)
LP Vapor, kg/hr. (lb./hr.)	
100%	4.3 (9.4)
75%	3.9 (8.7)
50%	3.4 (7.0)
25%	2.2 (5.2)

LP vapor conversion factors:

8.58 ft.³ = 1 lb.
0.535 m³ = 1 kg
36.39 ft.³ = 1 gal.

Nominal fuel rating:

Natural gas: 37 MJ/m³ (1000 Btu/ft.³)
LP vapor: 93 MJ/m³ (2500 Btu/ft.³)

Alternator

Alternator Features

- Compliance with NEMA, IEEE, and ANSI standards for temperature rise
- Self-ventilated and dripproof construction
- Vacuum-impregnated windings with fungus-resistant epoxy varnish for dependability and long life
- Superior voltage waveform and minimum harmonic distortion from skewed alternator construction
- Digital voltage regulator with $\pm 1.5\%$ no-load to full-load RMS regulation
- Rotating-field alternator with static exciter for excellent load response
- Skewed generator construction produces a smooth AC waveform

Alternator Specifications

Specifications	PowerBoost™ Generator 1-Phase
Manufacturer	Kohler
Output reconnectable	120/240
Type	2-Pole, Rotating Field
Leads, quantity	4
Voltage regulator	Digital
Insulation:	NEMA MG1-1.66
Material	Class H
Temperature rise	Class H
Bearing: quantity, type	1, Sealed Ball
Coupling	Direct
Amortisseur windings	Full
Voltage regulation, no-load to full-load RMS	$\pm 1.5\%$
One-step load acceptance	100% of Rating
Peak motor starting kVA	32

Controller

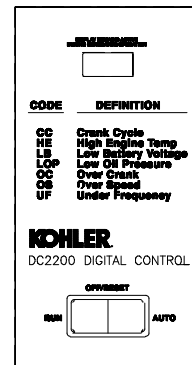

DC 2200 Digital Control Features

- Compact controller
- Integrally mounted to the generator set
- LED display:
 - Runtime hours
 - Crank cycle status
 - Diagnostics
- LED display communicates faults:
 - High engine temperature
 - Low battery voltage
 - Low oil pressure
 - Overcrank safety
 - Overspeed
 - Underfrequency
- Master switch: Run/Off-Reset/Auto
- Remote two-wire start/stop capability
- Superior electronics
- Digital voltage regulation: $\pm 1.5\%$ RMS no-load to full-load
- Automatic start with programmed cranking cycle

Prewire Kit

- 9 meter (30 ft.) wiring harness factory-connected to the generator set
- 120 VAC receptacle factory-installed inside the enclosure provides power to the battery charger and optional carburetor heater
- Flexible conduit with liquid-tight connectors protects all wiring from the generator set to the building
- Color-coded leads for ATS connections

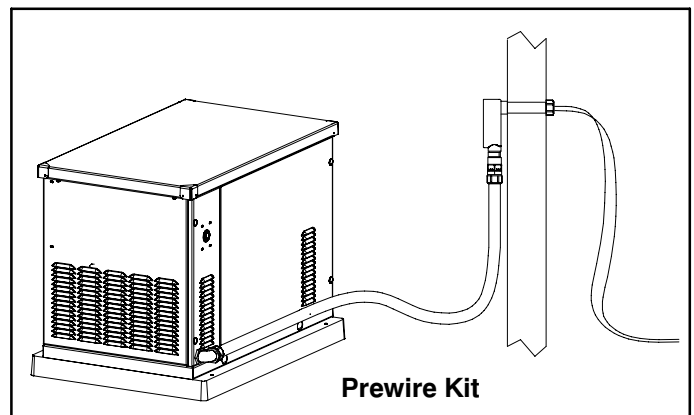

Standard Features

- Five-year limited warranty
- DC 2200 Digital Control
- Polymer base
- Battery cables
- Fuel solenoid valve and secondary regulator
- Line circuit breaker
- Oil drain extension with shutoff valve
- Critical silencer
- Sound enclosure, quiet 65 dB(A) operation
- Sound-deadening, flame-retardant foam per UL 94, class HF-1
- Rodent-resistant construction
- Spark arrester, USDA Forest Service-approved
- CARB- and EPA-certified fuel system
- Multi-fuel system, LP vapor/natural gas, field-convertible
- 6-amp battery charger
- Pre-wire kit
- Flexible fuel line

Available Power System Packages

- GM39503-SA1. Includes 12RESL/12RESM1 generator set with standard enclosure, pre-wire kit, and model RDT 100 amp automatic transfer switch with 12-circuit load center.
- GM39503-SA2. Includes 12RESL/12RESM1 generator set with standard enclosure and factory-installed carburetor heater, pre-wire kit, and model RDT 100 amp automatic transfer switch with 12-circuit load center.
- GM39503-SA3. Includes 12RESL/12RESM1 generator set with high-wind enclosure, pre-wire kit, and model RDT 100 amp automatic transfer switch with 12-circuit load center.
- GM39503-SA4. Includes 12RESL/12RESM1 generator set with high-wind enclosure and factory-installed carburetor heater, pre-wire kit, and model RDT 100 amp automatic transfer switch with 12-circuit load center.

Model RDT Automatic Transfer Switch

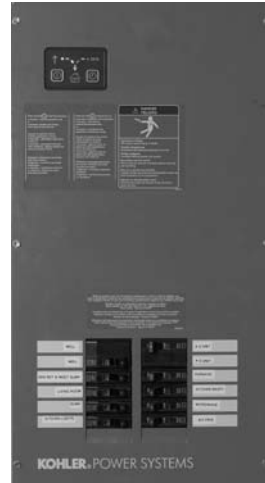

- 100 Amps, 240 VAC, 60 Hz
- 12-circuit load center
- UL 67 listed, file #E251086
- Equipped with MPAC™ 500 microprocessor-based controls
- User-friendly controller interface with easy-to-read international symbols
- See specification sheet G11-98 for more information

Dimensions and Weights

Overall Size, L x W x H: 1079 x 774 x 826 mm
 (42.5 x 30.5 x 32.5 in.)
 Weight: 186 kg (410 lb.)
 Shipping weight: 195 kg (430 lb.)

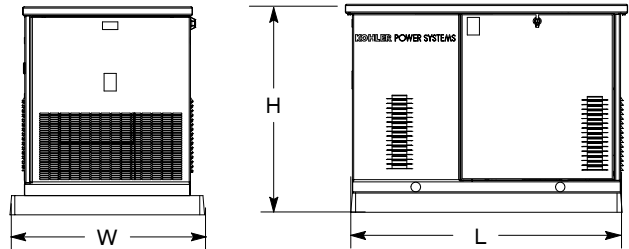

NOTE: This drawing is provided for reference only and should not be used for planning installation. Contact your local distributor for more detailed information.

DISTRIBUTED BY:

Alpine Group 877-232-0165
 PO Box 641 Salmon, ID 83467

AlpineSurvival.com
 security@alpinesthompson.com